

G.S.R. 254 – In exercise of the powers conferred by section 30 read with sections 14 and 17 of the Atomic Energy Act, 1962 (33 of 1962) and in supersession of the Atomic Energy (Control of Irradiation of Food) Rules, 1990 except as respects things done or omitted to be done before such supersession, the Central Government hereby makes the following rules, namely:-

1. Short title and commencement:-

- (1) These rules may be called the Atomic Energy (Control of Irradiation of Food) Rules, 1996.
- (2) They shall come into force on the date of their publication in the Official Gazette.

2. Definitions : In these rules unless the context otherwise requires:-

- (a) “Act” means the Atomic Energy Act, 1962 (33 of 1962),
- (b) “Applicant” means the person making an application for the grant of licence;
- (c) “Certificate of approval” means the certificate of approval granted by the competent authority for operating an irradiation facility in accordance with rule 5;
- (d) “Certificate of irradiation” means the certificate of irradiation issued by the licensee under rule 12;
- (e) “Certificate of release” means certificate of release issued by the licensing authority under rule 25;
- (f) “Competent authority” means such officer or authority directed by the Central Government under Section 27 of the Act to exercise the powers or discharge the duties under these rules;
- (g) “Dosimetry” means the method to measure the absorbed dose of radiation by the food;
- (h) “Food” means article of food referred to in column 2 of Schedule I;
- (i) “Form” means the Form annexed to these rules;
- (j) “Inspection Report” means the inspection report referred to in rule 10;
- (k) “Irradiation facility” means any facility which is capable of being utilised for the treatment of food by radiation;
- (l) “Irradiated food” means articles of food subjected to radiation by:-
 - (i) Gamma rays;

- (ii) X-rays generated from machine sources operated at or below an energy level of 5 million electron volts;
 - (iii) Sub-atomic particles, namely electrons generated from machine sources operated at or below an energy level of 10 million electron volts, to dose levels as specified in Schedule I.
- (m) “Licence” means licence for operating an irradiation facility issued under rule 4;
- (n) “licensee” means the person named in the licence in whose favour the licence is issued;
- (o) “Licensing authority” means the Central Government or such officer or authority directed by the Central Government under section 27 of the Act to grant license under section 14 of the Act;
- (p) “Operational Limits” means limits specified by the competent authority on the level of radiation to workers and members of the public and on the level of radioactive contamination from the radioactive sources used in the irradiation facility;
- (q) “Operator” means any person, appointed as such by the licensee and who shall have the qualification and other requirements as specified in paragraph 2 of Schedule II;
- (r) “Quality Control Officer” means any person appointed as such by the licensed who shall have the qualification and other requirements as specified in paragraph 3 of Schedule II;
- (s) “Radiological Safety Officer” means any person appointed as such by the licensee who have the qualification and other requirements as specified in paragraph 1 of Schedule II;
- (t) “Schedule” means “Schedule annexed to these rules”
3. Conditions precedent for the issue of a licence:- No licence for operating an irradiation facility shall be granted, unless the applicant obtains a certificate of approval from the competent authority, after submitting documents as specified in Schedule III to the effect that the facility is in conformity with the general conditions for design, operation and efficiency criteria as specified in Schedule IV.
4. Licence:-

- (1) An application for a licence shall be made to the licensing authority in Form I and shall be accompanied by:-
 - (a) a certificate of approval;
 - (b) fee of rupees five hundred payable in the form of a bank draft drawn in favour of the licensing authority;
- (2) If the licensing authority is satisfied that the applicant is capable of operating an irradiation facility in accordance with these rules, it shall issue a licence in Form IV.
- (3) If the licensing authority is satisfied that the applicant is not capable of operating an irradiation facility in accordance with these rules, it may, after giving the applicant reasonable opportunity of being heard against the proposed refusal of licence, by order setting out the reasons therein, refuse to grant the licence.
- (4) Every order refusing to grant the licence sub-rule (3) shall be communicated to the applicant, by sending a copy of the order by registered post to the address given in the application.

5. Certificate of approval:-

- (1) An application for a certificate of approval shall be made to the competent authority in Form III.
- (2) If the competent authority is satisfied that the applicant satisfies the requirements as specified in Schedule III and IV, it shall grant a certificate of approval in Form II.
- (3) If the competent authority is satisfied that the applicant does not satisfy the requirements as specified in Schedule III and IV, it may, after giving the applicant a reasonable opportunity of being heard against the proposed refusal of the certificate of approval, by order, setting out the reasons therein, refuse to grant the certificate of approval.
- (4) Every order refusing to grant the certificate of approval under sub-rule (3), shall be communicated to the applicant by sending a copy of the order by registered post to the address given in the application.

6. Power to suspend the certificate of approval :

- (1) If the competent authority is satisfied, on the basis of the inspection report, that any irradiation facility has ceased to conform to the safety and efficiency criteria as specified in Schedule IV; it may for reasons to be recorded in writing, make

and order suspending the certificate of approval and call upon the licensee to rectify the defects mentioned therein within a period of thirty days from the date of receipt of the order.

- (2) The order of the competent authority made under sub-rule (1) along with the copy of the inspection report shall be communicated to the licensee who shall on receipt of the same, cease to operate the irradiation facility until the suspension of the certificate of approval is revoked under sub-rule (5).
- (3) The competent authority shall transmit copies of the order and inspection report referred to in sub-rule (2) to the licensing authority.
- (4) The competent authority shall enter in the certificate of approval the particulars of inspection.
- (5) Where the competent authority is satisfied that pursuant to the order made under sub-rule (1) the licensee has rectified the defects mentioned therein, it may revoke the suspension of the certificate of approval and communicate in writing the decision to the licensee.
- (6) If the defects mentioned in the order are not rectified by the licensee within the period mentioned therein, the competent authority shall report the matter to the licensing authority for necessary action.
- (7) Any person aggrieved by the order of suspension of certificate of approval by the competent authority may within a period of fifteen days from the receipt of the communication of such suspension prefer an appeal to the Atomic Energy Commission.

7. Power to suspend the Licence:-

- (1) If the licensing authority is satisfied, on the basis of the inspection report that the licensee has failed to ensure that the irradiation facility under his control conforms to the safety and efficiency criteria specified in Schedule IV, it may for reasons to be recorded in writing make an order suspending the licence and call upon the licensee to rectify the defects mentioned therein within a period of thirty days from the date of receipt of the order.
- (2) The period of thirty days stipulated under sub-rule (1) of rules 6 and 7 may be condoned by the licensing authority after having satisfied himself with the fact that the licensee is not able to rectify the defects for reasons beyond his control within the stipulated period of thirty days.
- (3) The order made by the licensing authority under sub-rule (1) along with the copy of the inspection report shall be communicated to the licensee, who shall on

receipt of the same, cease to operate the irradiation facility until the suspension of the licence is revoked.

- (4) Where the licensing authority is satisfied that pursuant to the order made under sub-rule (1), the licensee has rectified the defects mentioned therein, it may revoke the suspension of the licence and communicate the decision to the licensee.
 - (5) Any person aggrieved by the order of suspension or revocation of a licence by the licensing authority may within a period of fifteen days from the receipt of the communication of such suspension or revocation prefer an appeal to the Central Government.
8. Revocation of licence:- Notwithstanding anything contained in rule 4, the licensing authority may after giving the licensee a reasonable opportunity of being heard, by order setting out the reasons therein in writing, revoke any licence or modify the terms and conditions of any licence on any of the following grounds, namely:-
- (1) Where the certificate of approval has been suspended and the competent authority has reported that the licensee has not rectified the defects mentioned in the order of suspension within the period stipulated therein; or
 - (2) Where the licence has been suspended and the licensee has not rectified the defects mentioned in the order of suspension within the period stipulated therein; or
 - (3) Where in the opinion of the licensing authority, it is necessary to do so, in order to ensure safety of persons whosoever may suffer any injury because of any negligence in the process of irradiation.
9. Conditions for irradiation of food:-
- (1) The licensee shall not undertake irradiation of any food unless in his opinion such irradiation is necessary for its preservation, protection against parasites or improvement of its hygienic or technological quality.
 - (2) The licensee shall ensure that:-
 - (a) the Quality Control Officer has satisfied himself that the food to be irradiated is of good quality.
 - (b) in the case of packaged products, the packing material conforms to the standards specified in Schedule VII.
 - (c) the irradiated food is readily identified so as to prevent it from being subjected to subsequent irradiation

(d) the dose limit, radiation source and irradiation conforms to the conditions specified in Schedules I and V.

(e) the irradiation facility is operated only by the operator

10. Period Inspection of facilities:-

(1) The competent authority or any person authorised by him in this behalf shall undertake inspection of the irradiation facility at least twice in a year, but the maximum gap between two inspections shall not exceed 8 months.

(2) The particulars of the inspection shall be recorded by an entry on the certificate of approval

(3) A copy each of the inspection report shall be forwarded to the licensee and to the licensing authority

11. Record of food irradiation:-

(1) The licensee shall maintain, for each source of radiation used, a record in Form V indicating, for each batch of food subjected to radiation treatment:-

(a) the serial number of the batch;

(b) the date of irradiation;

(c) the nature and the quality of irradiated food and the batch number;

(d) the type of packaging used during the radiation treatment in the case of packaged products;

(e) the control and measurement performed during the treatment, particularly as regards the minimum and maximum limits of radiation dose;

(f) where appropriate, all supplementary information required by the specific irradiation conditions provided for in Schedule V;

(g) any incidents and anomalies observed during the irradiation treatment.

(2) The record shall contain the names and address of the operators and the quality control officer and the identification number of the irradiation facility.

(3) The licensee shall retain the records for a period of five years.

- (4) The licensee shall maintain the record of standard model for the food irradiation in respect of each batch of food as specified in Form V.
12. Certificate of irradiation:-
 - (1) The licensee shall, on the basis of the data entered in the record of irradiated food, issue a certificate of irradiation for every batch of food item which has undergone irradiation in his facility.
 - (2) A copy of the certificate of irradiation shall be maintained by the licensee.
13. Irradiation voucher:- The licensee shall issue to the person from whom an order for the irradiation of food has been received, an irradiation voucher for each batch of food containing the following particulars, namely:-
 - (1) the identification number of the irradiation facility together with the names and addresses of the operator and quality control officer;
 - (2) the nature and quality of the batch of irradiated food and also the purpose of the irradiation;
 - (3) the date of the radiation treatment;
 - (4) the radiation source used and specific dose of radiation;
 - (5) the serial number of the batch which has been subjected to the treatment which number must correspond to the information in the irradiation record;
 - (6) date and signature of the licensee.
14. Maintenance of log books:- Every licensee shall maintain and make available to any person duly authorised by the competent authority for inspection, a log book containing the following particulars, namely:-
 - (1) description of the facility;
 - (2) source details;
 - (3) the name of supplier of the source and his address;
 - (4) the identity of Radiological Safety Officer (RSO).
15. Control of irradiation facility:-

- (1) The competent authority or any person authorised by him in his behalf shall undertake verification to ensure that the operation of the facility and the use of radiation treatment procedures conform to the general and specific conditions as specified in Schedule IV.
 - (2) The licensee shall provide all reasonable facilities to the competent authority or any person authorised by him, to carry out inspection and measurement procedures as may be necessary.
16. Powers and duties of person authorised to inspect:- (1) The competent authority or any person authorised by him in this behalf shall-
- (a) have the right of access:-
 - (i) to any place which is used for irradiation of food or for storage of food which has been or has to be irradiated;
 - (ii) to all documents relating to the irradiation facility, the batches of food which have been or are to be irradiated, a certificate of approval, the copies of the inspection report, order of suspension, modification or revocation of licence, food irradiation records and the documents relating to purchase and sale accompanying the batches of food.
 - (b) to check the performance of the irradiation unit and measure the dosage to which the food is subject to.
17. Radiological Safety Officer:- The qualifications of Radiological Safety Officer are given in Schedule II. No person shall be appointed as a Radiological Safety Officer unless such person:-
- (1) possesses a certificate towards his qualification by an institution or authority approved by the competent authority.
 - (2) is familiar with the operating and emergency procedures of the irradiation unit and has demonstrated his understanding thereof to the satisfaction of the competent authority.
 - (3) is familiar with the rules, notification and orders applicable to the irradiation facility and has demonstrated his understanding thereof to the satisfaction of the competent authority.
 - (4) has demonstrated to the satisfaction of the Competent authority competence to use the irradiation facility and the radiation instruments to be used in his assignment..
18. Duties of Radiological Safety Officer: The Radiological Safety Officer shall –

- (1) instruct the radiation workers under his charge on the hazards of radiation and on suitable safety measures and work practices aimed at minimising exposure to radiation;
- (2) take all necessary steps aimed at ensuring that the operational limits as specified in Schedule VIII are not exceeded;
- (3) carry out leakage tests as specified by the competent authority in Schedule IX and tests of safety related systems;
- (4) investigate and initiate prompt and suitable remedial measures in respect of any situation that could result in radiation hazard;
- (5) ensure that reports on all hazardous situation along with details of any immediate remedial measures that may have been initiated, are made available immediately to his employer;
- (6) assist the licensee in the safe disposal of decayed radioactive sources in the manners approved by the competent authority.

19. Monitoring of personnel:- The licensee shall ensure that:-

- (1) every person entering the irradiation facility wears separate personnel monitoring device provided by him.
- (2) such personnel monitoring devices are processed by an agency approved by the competent authority.
- (3) investigation reports regarding all excessive exposures are forwarded to the competent authority.
- (4) the workers exposed to radiation have been medically examined as specified by the competent authority.

20. Operating procedures:- The licensee shall prepare a detailed operating procedure based on the manufacturer's manual which shall inter alia provide that:-

- (1) the irradiation facility shall be operated only in such a way that no person is likely to be exposed to radiation doses in excess of the operational limits notified by the competent authority.
- (2) it shall be impossible to resume operation of irradiation facility after the return of the source to the fully shielded position without complying with the requirements such as interlocked controls for personnel access, radiation room lock-up sequence and source exposing operations.

- (3) a single multipurpose key which is to operate the control console, to gain access to the radiation room and to activate safety related interlocks is available.
 - (4) The procedures and occasions for conducting radiation surveys and contamination tests, are devised.
 - (5) The procedures for locking and the use of facility are available.
 - (6) Monitoring of the personnel and the use of area monitoring equipment is made mandatory.
 - (7) Transportation of sealed sources used in irradiation unit is undertaken in a safe manner.
 - (8) Records are maintained in proper form.
 - (9) For inspection and maintenance procedures, approved by the competent authority, are devised for the radiation facility.
 - (10) In the event of an accident persons to be notified in accordance with the procedure specified by the competent authority.
 - (11) The radiation zone monitor is so integrated with the personnel access door interlocks to prevent room access of specified values or if the detector malfunctions or is turned off.
 - (12) The monitor shall also generate audible and visible alarm signals if the radiation level exceeds that when source is in the fully shielded position.
21. Emergency procedures:-
- (1) The licensee shall prepare detailed emergency procedures for each type of emergency that may reasonably be anticipated.
 - (2) The procedure should be brief and should be expressed in the form of instructions which can be understood by non-technical persons.
 - (3) The procedures should describe situations requiring emergency action and specify immediate action to be taken to minimise radiation dose to persons in the vicinity of the irradiation facility.
22. Security of irradiation facility:- The licensee shall ensure that during the operation of the irradiation facility, direct surveillance of the facility is maintained in order to prevent unauthorized entry licensee shall conspicuously display the radiation onto the facility.

23. Posting of radiation warning signs:- The warning sign as given below at the site in which irradiation is in progress

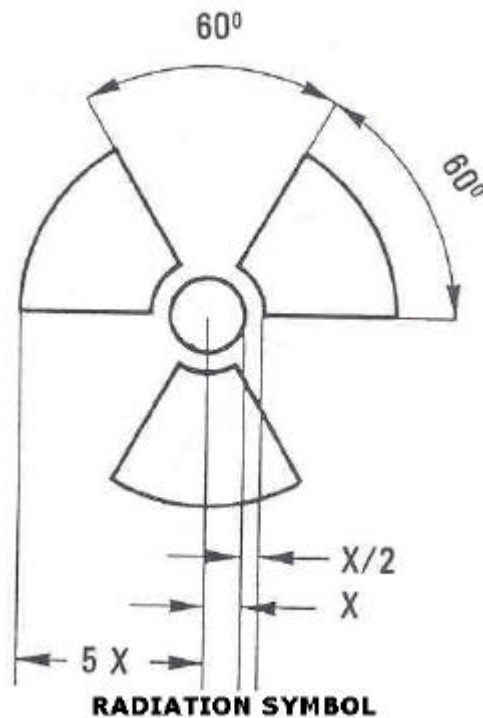

BASIC TREFOIL SYMBOL WITH PROPORTIONS BASED ON A CENTRAL CIRCLE OF RADIUS X . THE MINIMUM ALLOWABLE SIZE OF X SHALL BE 4 mm.

24. Radiation survey instruments:- The licensee shall not commence operation of any irradiation facility under his control unless the irradiation facility is equipped with instruments as specified by the competent authority in Schedule VI.

25. Decommissioning:-

- (1) No licensee, shall decommission any irradiation facility under his control unless he:-
 - (a) obtains the previous permission of the licensing authority
 - (b) undertakes to decommission the irradiation facility in the manner specified by the competent authority
 - (c) undertakes to bear all the expenses of such decommissioning
- (2) The licensee shall not use the site used for the irradiation facility for any other purpose, unless he obtains the certificate of release from the licensing authority.

- (3) The licensing authority may on the application of the licensee and after obtaining a report from the competent authority, in its discretion issue a certificate of release.
26. Disposal of decayed sources: - The licensee shall at his expense, ensure the safe disposal of the radioactive sources in such manner as may be approved by the competent authority.

SCHEDULE I

[See rules 2 (h) and 9(2)(d)]
Technological conditions for irradiation

Sl. No.	Name of food	Purpose of irradiation	Dose (kGy)			Specific conditions
			Minimum	Maximum	Overall average	
(1)	(2)	(3)	(4)	(5)	(6)	(7)
1.	Onions	To inhibit sprouting	0.03 (30 Gy)	0.09 (90 Gy)	0.06 (60 Gy)	
2.	Potatoes	To inhibit sprouting	0.06 (60 Gy)	0.15 (150 Gy)	0.10 (100 Gy)	
3.	Frozen sea- foods	To reduce the number of certain pathogenic microorganisms such as Salmonella in packaged frozen sea-foods.	4	6	5	Irradiation should be carried out in a frozen state
4.	Spices	To control insect infestation to reduce microbial local and pathogenic microorganisms	6	14	10	Irradiation under prepacked condition

SCHEDULE II

[see rule 2(q), (r) and (s)]

Qualifications of Personnel

1. Radiological Safety Officer: The minimum qualification: He should be a Science graduate with physics as one of the subjects.

He should have also successfully undergone instructions specified for the training of Radiological Safety Officer. He should have also successfully undergone instructions specified for the training of Radiological Safety Officer level III as prescribed by Atomic Energy Regulatory Board and should possess a valid certificate to that effect. The subject

for instructions include fundamentals of radiation and radiation protection, concept of dose limit, use of instruments and survey techniques in radiation detection; and knowledge of personnel monitoring equipment, inspection and maintenance of safety interlocks, and operation and emergency procedures.

2. Operator:- The operator should be Science graduate/ Diploma holder either in Electrical or Mechanical Engineering.

The subject for inclusion in the instruction of the operator will be the same as those prescribed for Radiological Safety Officer except that he shall be given training in elements of food technology and food irradiation technology also.

Food Irradiation Technology:-

- (a) Details of radiation sources used for food irradiation.
 - (b) Measurement of absorbed doses during irradiation using proper dosimeter for various types of sources and maintenance of the record of dosimetry and source activity.
 - (c) Source-product geometry to increase efficiency of radiation utilization.
 - (d) Operation of radionuclide irradiator to ensure correct operational and of correct safe position operational and of correct safe position of the source which should be interlocked with the product movement.
 - (e) Maintenance of irradiator.
 - (f) Irradiation technology of individual food items.
3. Quality Control Officer:- The qualification of the Quality Control Officer should be either M.Sc./B. Tech in Microbiology, Food Technology or Food Chemistry
 - (1) The Quality Control Officer shall ascertain the quality of the food.

SCHEDULE III (see rule 3)

Document to be submitted to the competent authority for obtaining approval of irradiation facilities.

The applicant shall submit to the competent authority:-

- (1) The complete design drawings of the facility indicating the details of the shielding surrounding the source, wall thickness, labyrinth access, openings voids, reinforcements, mechanical and electrical safety system, ventilation, fire protection systems.
- (2) The environs of the facility including residential complexes, occupancy within 50m radius of the facility, geology of the location, water table, soil characteristics, seismicity.
- (3) Complete description of the radiation source, address of the supplier and the operating condition of the source such as source drive system.
- (4) Safety analysis report to demonstrate the adequacy of radiation safety under normal and anticipated accident conditions.

SCHEDULE IV
(See rules 3 and 6)

A. Condition for the operation of irradiation facilities.

1. Introduction:-

- 1.1 Only irradiation facilities based on the use of either a radionuclide source (^{60}Co or ^{137}Cs) or X-rays and electrons generated from machine sources should be used.
- 1.2 The Irradiation facility, may be of two designs either “continuous” or “batch” type.
- 1.3 The irradiation facility shall make use of accepted methods for measuring the absorbed radiation dose and of the monitoring of the physical parameters of the process.

2. Irradiation plants:-

- 2.1 The manufacturers of the facility should state the activity of the source in Becquerel (Bq) in the case of radionuclide source, and it should be recorded. The recorded activity should take into account the natural decay rate of the source and should be accompanied by a record of the date of measurement of recalculation.
- 2.2 The irradiation facility using radionuclide sources shall have a well separated and shielded depository for the source element and a treatment areas which can be entered only when the source is in the safe position.

- 2.3 There should be a positive indication of the correct operational and of the correct safe position of the same which should be interlocked with the product movement system.
 - 2.4 In the case of machine sources the average beam power should be adequately recorded.
 - 2.5 There should be a positive indication of the correct setting of all machine parameters which should be interlocked with the product movement system.
 - 2.6 A beam scanner or a scattering device (e.g. the converting target) must be incorporated in a machine source to obtain an even distribution of the radiation over the surface of the product.
 - 2.7 The product movement, with width and speed of the scan and the beam pulse frequency (if applicable) should be adjusted to ensure a uniform surface dose.
3. Dosimetry and Process Control:-
- (1) Certain dosimetry measurements (para.B) should be made prior to the irradiation of any food stuff.
 - (2) The dosimetry measurement should be done for each new food irradiated, irradiation process, and whenever modifications are made to source strength or type and to the source product geometry.
 - (3) Routine dosimetry should be made during operation and records of such measurements must be available for inspection.
 - (4) The measurements of facility parameters governing the process such as transportation speed, dwell time, source exposure time, machine beam parameters, should be made regularly during the operation and record must be kept for inspection.
4. Good radiation processing practices:-
- (1) The design of the irradiator should have the facility to optimize the dose uniformity ratio to ensure appropriate dose rates and where necessary to permit temperature control during irradiation (e.g. for treatment of frozen food) and also control of atmosphere.
 - (2) Care must be exercised to minimize mechanical damage to the product during transport, irradiation and storage and to use irradiator to its maximum efficiency.
 - (3) Where the food to be irradiated is subjected to special standards for hygiene or temperature, control, the facility must permit compliance with these standards.

5. Product and Inventory Control:-

- (1) The incoming product should be physically separated from the outgoing irradiated product.
- (2) Where appropriate a visual colour change radiation indicator should be affixed to each product pack for ready identification of irradiated and non-irradiated products.
- (3) Records should be kept in the facility record book which show the nature and kind of the product being treated, its identifying marks if packed or, if not, the shipping details, its bulk density, the type or source of electron machine, the dosimetry, the dosimeters used and details of their calibration, and the dates of the treatment.
- (4) All products shall be handled, before and after irradiation, according to accepted good manufacturing practices taking into account of the particular requirements of the technology or the process (Schedule I). Suitable facilities for refrigerated storage may be required.

B. DOSIMETRY

1. The overall average absorbed dose: It can be assumed for the purpose of the determination of the wholesomeness of food treated with an overall average dose of 10 kGy or less, that all radiation chemical effects in that particular dose range are proportional to dose.

The overall average dose, D , is defined by the following integral over the total volume of the goods

$$D = \frac{1}{M} \int \Gamma(x, y, z), d(x, y, z).dv$$

Where

M = the total mass of the treated sample

Γ = the local density at the point (x,y,z)

d = the local absorbed dose at the point (x,y,z)

$dv = dx dy dz$ the infinitesimal volume element which in real case is represented by the volume fractions.

The overall average absorbed dose can be determined directly by homogenous products or for bulk goods of homogeneous bulk density by distributing an adequate number of dose meters strategically and at random throughout the volume of the goods. From the dose distribution determined in this manner an average can be calculated which is the overall average absorbed dose.

If the shape of the dose distribution curve through the product is well determined the positions of minimum and maximum dose are known. Measurements of the distribution of dose in these two positions in a series of samples of the product can be used to give an estimate of the overall average dose.

In some cases the mean value of the average values of the minimum (Dmin) and maximum (Dmax) dose will be a good estimate of the overall average dose, i.e. in these cases

$$\text{Over average dose} = (D_{\text{max}} + D_{\text{min}}) / 2$$

2. Effective and limiting dose values

- (1) Some effective treatment e.g. the elimination of harmful microorganisms or a particular shelf-life extension or a disinfection requires a minimum absorbed dose. For other applications too high an absorbed dose may cause undesirable effects or an impairment of the quality of the product.
- (2) The design of the facility and the operational parameters have to take into account minimum and maximum dose values required by the process. In some low dose applications it will be possible within the terms of paragraph 4 on Good Radiation Processing Practice to allow a ratio of maximum to minimum dose of greater than 3.
- (3) With regards to the maximum dose value under acceptable wholesomeness considerations and because of the statistical distribution of the dose of mass fraction of product of at least 97.5% should receive an absorbed dose of less than 15 kGy when the overall average dose is 10 kGy.

3. Routine dosimetry

Measurements of the dose in a reference position can be made occasionally throughout the process. The association between the dose in the reference position and the overall average dose must be known. These measurements should be used to ensure the correct operation of the process. A recognized and calibrated system of dosimetry should be used.

A complete record of all dosimetry measurements including calibration must be kept.

4. Process Control

- (1) In the case of a continuous irradiation facility employing radionuclide, it will be possible to make automatically a record of transportation speed or dwell time together with indications of source and product positioning. These measurements can be used to provide a continuous control of the process in support of routine dosimetry measurements.

- (2) In a batch operated radionuclide facility automatic recording of source exposure time can be made and a record of product movement and placement can be kept to provide a control of the process in support of routine dosimetry measurements.
- (3) In a machine facility a continuous record of beam parameters, e.g. voltage, current, scan speed, scan width, pulse repetition and a record of transportation speed through the beam can be used to provide a continuous control of the process in support of routine dosimetry measurements.

SCHEDULE V
[See rule 9(2)(d)]

General conditions for Irradiated Foods

1. SCOPE

These conditions applies to foods processed by irradiation. It does not apply to foods exposed to doses imparted by measuring instruments used for inspection purposes.

2. GENERAL CONDITIONS FOR THE PROCESS

(1) Radiation Source :

The following types of ionizing radiation may be used:-

- (a) Gamma rays from the radionuclides ^{60}Co or ^{137}Cs ;
- (b) X-rays generated from machine sources operated at or below an energy level of 5 MeV;
- (c) Electrons generated from machine sources operated at or below an energy level of 10 MeV.

(2) Absorbed Dose:

The overall average dose absorbed by a food subjected to radiation processing should not exceed 10 kGy.

(3) Facility and Control of the Process

2.3.1 Radiation treatment of foods shall be carried out in facilities licenced and registered for this purpose by the licensing authority.

2.3.2 The facilities shall be designed to meet the requirements of safety, efficacy and good hygienic practices of food processing.

2.3.3 The facilities shall be staffed by adequately trained and competent personnel.

2.3.4 Control of the process within the facility shall include the keeping of adequate records including quantitative dosimetry.

2.3.5 Premises and records shall be open to inspection by appropriate national authorities.

3. TECHNOLOGICAL REQUIREMENTS:

(1) Conditions for Irradiation:

The irradiation of food is justified only when it fulfills a technological need.

(2) Food Quality and Packaging Requirements :

The doses applied shall be commensurate with technological and public health purposes to be achieved and shall be in accordance with good radiation processing practice. Foods to be irradiated and their packaging materials shall be of suitable quality, acceptable hygienic conditions and appropriate for this purpose and shall be handled, before and after irradiation, according to good manufacturing practices taking into account the particular requirements of the technology of the process.

4. LABELLING

(1) Inventory control:

For irradiated foods, whether prepacked or not, the relevant shipping documents shall give appropriate information to identify the registered facility which has irradiated the food, the date(s) of treatment and lot identification.

(2) Prepacked foods intended for direct consumption:

The labelling of prepackaged irradiated foods shall be in accordance with the relevant provisions given in Prevention of Food Adulteration Rules.

(3) Food in bulk containers:

The declaration of the fact of irradiation shall be made clear on the relevant shipping documents.

5. RE-IRRADIATION

- (1) Except for foods with low moisture content (cereals, pulses, dehydrated foods and other such commodities) irradiated for the purposes of controlling insect reinfestation, foods irradiated in accordance with 2 and 3 of this standard shall not be re-irradiated.
- (2) For the purpose of this standard food is not considered as having re-irradiated when
 - (a) the food prepared from materials which have been irradiated at low levels e.g. about 1 kGy, is irradiated for another technological purpose;
 - (b) the food containing less than 5% of irradiated ingredient, is irradiated, or when
 - (c) the full dose of ionizing radiation required to achieve the desired effect is applied to the food is more than one instalment as part of processing for a specific technological purpose.
- (3) The cumulative overall average dose absorbed should not exceed 10 kGy as a result of re-irradiation.

SCHEDULE VI
[See Rule 24]

Radiation Survey Instruments required for radiation monitoring.

Either

- A.
 1. Radiation Survey Meter (G.M. Type 0.2 mR/hr or with other appropriate measurement range)
 - and
 2. Radiation Survey Meter (Ionization chamber type 0-5R/hr. or with other appropriate measurement range)
 - or
- B.
 1. Wide range Survey Meter (G.M. Type 0-100R/hr. or with other appropriate measurement range)

2. Alternatively, any single or combination of radiation survey meters recognised by the competent authority as equivalent to the above.

SCHEDULE VII
[See Rule 9(1)(b)]

Standards of packaging material:

1.
 - (1) Where packing is essential to prevent post-treatment recontamination, the food should be packed before treatment.
 - (2) Package size especially with bulk packs should be such that they can be handled efficiently thereby avoiding excessive delays and temperature abuse.
 - (3) The choice of the packing material and the nature of the container for specific food is usually determined by the purpose they are to serve and storage conditions, such as prevention of moisture loss or moisture uptake, to provide an atmosphere devoid of air, or to avoid mechanical damage to food.
 - (4) Sterilized food must have containers which prevent access to bacteria or other micro-organisms.

2. Rigid Containers:
 - (1) Primary rigid container used for irradiated food is metal can, Steel containers, tin-plated and lined with appropriate enamel such as polybutadiene or epoxy-phenolic have been found to be satisfactory.
 - (2) Secondary rigid containers made of wood, fibre board or glass are also used.

3. Flexible packaging material:- Flexible plastic containers because of their low density are highly suitable for packing irradiated food. Films over 76 cm thick are satisfactory for preservation of irradiated products. In case laminates are used their performance should satisfy the following criteria:-
 - (i) The films are not changed adversely:-
 - (a) in their protective characteristics (e.g. seal stability, permeability, etc),

- (b) by radiation induced changes in the food,
 - (c) causing transmission of toxic or potentially toxic, and substances to the food.
- (ii) Polymeric films recommended for use upto 10 kGy are:-
- (a) Nitrocellulose or vinylidene coated cellophane;
 - (b) Wax coated paper board;
 - (c) Glassine paper;
 - (d) Polystyrene;
 - (e) Rubber hydrochloride;
 - (f) Vinylidene chloride – vinyl chloride;
 - (g) Polyethylene;
 - (h) Polyethylene terephthalate;
 - (i) Nylon 6;
 - (j) Nylon 11;
 - (k) Vinyl chloride – vinyl acetate
 - (l) Vegetable parchment

SCHEDULE VIII
[See Rule 18(2)]

Operational Limits:

Effective Dose Limits:-

1. The cumulative effective dose constraint for five years from January 1, 1994 to December 31, 1998 will be one hundred milli Sievert (100 mSv) for individual radiation workers.
2. The annual effective dose to individual workers in any calendar year during the five-year block shall not exceed the limit of thirty milli Sievert (30 mSv).

SCHEDULE IX
[See Rule 18(3)]

Leakage and safety related tests.

1. Wet storage irradiators:

- (1) The resin bed in the water conditioning system shall be daily checked with a radiation survey instrument. The survey instrument should be sensitive enough to detect minimum radioactive of 2000 Eq. in the resin bed. In the event of detection of activity above this level, water circulation system shall be stopped and irradiator shall be withdrawn from service.
- (2) In addition the pool water shall be checked for contamination by using an on-line radiation monitor on a pool water circulating system.
- (3) The detection of above normal radiation levels must activate an alarm. Activation of alarm must automatically cause the water purification system to shut off.

2. Dry storage irradiators :

Swipe test using a moist paper of 100 square centimeter area shall be conducted weekly on the closest accessible surface near the source in storage condition. Activity on the sample shall be counted by a radiation survey instrument with a minimum detection capability of 2000 Bq on swipe sample. In the event of detection of activity above this level, irradiator shall be withdrawn from service.

Form I
[See rule 4(1)]

APPLICATION FOR OBTAINING A LICENCE FOR AN IRRADIATION FACILITY

1. Name of the applicant
2. Address of the applicant
3. Installation for which approval is applied for
4. Name and designation of the Head of Installation
5. Names, qualifications and experience of Personnel

Category of Personnel	Name	Academic Qualification	Type of training experience	When and where trained	Duration of training
Operator Radiological Safety Officer Quality Control Officer					

6. Proposed date of starting the Irradiation Facility:

7. Details about the Irradiation Facility:

- (1) Identification number of the facility
- (2) Location and address
- (3) Source details

Name of radionuclide	Activity
Radiation generating plant	Energy output
X-ray unit	
Electron Accelerator	

- (4) Name of the supplier and his address
- (5) Purpose for which the irradiation facility will be used

8. Please attach the following additional information to the application:

- (1) A site plan (1:500 scale or as appropriate) of the installation indicating the location of building including residential complexes.
- (2) Architectural blue prints (appropriate scale) showing layout of equipment.
- (3) Complete design drawing of the facility including details of
- (4) Description of the organisational structure including delegation of authority and responsibility for operations at the facility.

9. Please indicate as appropriate:

- (1) the irradiation facility is yet to be built
- (2) the irradiation facility is already built and equipped
- (3) Existing irradiation facility is to be modified as per details enclosed.

10. I hereby certify that:

- (1) all the statements made above are correct to the best of my knowledge and belief.
- (2) no operations will be carried out for purposes other than those specified under item 7 (5) of this form.
- (3) all provisions of the Atomic Energy (Control of Irradiation of Food) Rules, 1996 shall be strictly complied with.
- (4) the irradiation facility shall not be transferred/sold/rented by me/ us to another without the prior permission of the competent authority.
- (5) no radiation sources for the irradiation unit will be transported without the prior permission of the competent authority.
- (6) full facilities will be accorded by me/us to any authorised representatives of the competent authority or licensing authority to inspect the installation at any time.
- (7) radiation surveillance and medical surveillance of all persons engaged in radiation work as required by the competent authority will be duly carried out at my/our expense.
- (8) all recommendations that may be made from time to time by the competent authority in respect of radiation safety measures will be duly implemented.
- (9) duly qualified/experienced radiological safety officers will be appointed before the commencement of the operation of the facility.
- (10) any change in the personnel listed in this application will be intimated forthwith to the licensing authority and the competent authority.
- (11) the rules regarding decommissioning, disposal of decayed sources and rules of the site of the decommissioned facility shall be strictly complied with.

Date:

Signature of the Applicant Institution and Seal

FORM II
[See rule 5 (2)]

CERTIFICATE OF APPROVAL FOR IRRADIATION FACILITY

Mr./Messers
Of

having complied with the conditions prescribed in the Atomic Energy (Control of Irradiation of Food) Rules, 1996 for the approval of the irradiation facility is/are hereby granted the certificate of approval for his/their irradiation facility.

The description of the irradiation facility and other details are shown as under:

1. Identification Number
2. Name and Addresses
 - (i) Licensee
 - (ii) Radiological Safety Officer
 - (iii) Quality Control Officer

- (iv) Operator
- 3. Kind and nature of the food product to be irradiated
- 4. Radiation source used
 - (i) Type of source
 - (ii) Total activity content in the case of radionuclide sources
 - (iii) Type of operation
 - Batch
 - Continuous
 - (iv) Source product geometry
 - (v) Dose rate
- 5. Specific operation conditions

COMPETENT AUTHORITY
(Seal of Office)

- (3) Details on geology of the location, water table, soil characteristics, seismicity.
 - (4) Complete design drawing of the facility including details of shielding surrounding of source, wall thickness and labyrinth access if applicable; openings, voids, reinforcements, mechanical and electrical safety systems, ventilation. Fire protection systems.
 - (5) Source movement system (where appropriate).
 - (6) Safety analysis report to demonstrate the adequacy of radiation safety under normal and anticipated accident condition as detailed in rules 20 and 21.
 - (7) Operating and emergency procedures.
 - (8) List of calibrated radiation monitoring equipment in working condition.
 - (9) Description of the organisational structure including delegation of authority and responsibility for operation of the facility.
9. Any other information which the competent authority may deem necessary to assess the safety status of the irradiation facility.
10. Please indicate as appropriate:
- (a) the irradiation facility is yet to be built
 - (b) the irradiation facility is already built and equipped
 - (c) existing irradiation facility is to be modified as per details enclosed.
11. I hereby certify that:
- (1) all the statements made above are correct to the best of my knowledge and belief.
 - (2) no operations will be carried out for purposes other than those specified under item 7(5) of this form.
 - (3) all provisions of the Atomic Energy (Control of Irradiation of Food) rules, 1996, shall be strictly complied with.
 - (4) the irradiation facility shall not be transferred/sold/rented by me/us to another without the prior permission of the competent authority.
 - (5) no radiation source for the irradiation unit will be transported without the prior permission of the competent authority.
 - (6) full facilities will be recorded by me/us to any authorized representatives of the competent authority or the licensing authority to inspect the installations at any time.
 - (7) radiation surveillance and medical surveillance of all persons engaged in radiation work as required by the competent authority will be duly carried out at my/our expense.
 - (8) all recommendations that may be made from time to time by the competent authority in respect of radiation safety measures will be duly implemented.
 - (9) duly qualified/ experienced radiological safety officers/ operators/ quality officers will be appointed before the commencement of the operation of the facility.
 - (10) the rules regarding decommissioning disposal of decayed sources and reuse of the site of the decommissioned facility shall be strictly complied with.

Date:

Signature of the Applicant
Seal of the Institution

FORM IV

[See rule 4 (2))

LICENCE FOR OPERATING AN IRRADIATION FACILITY

Mr./Messers
Of.....
..... having undertaken to comply with all the conditions prescribed in the Atomic Energy (Control of Irradiation of Food) Rules. 1996 after having paid the prescribed licence fee and having obtained the certificate of approval from the competent authority is/are hereby authorised to commission and operate the irradiation facility described in the application for licence.

This licence is issued on and shall be valid upto..... subject to conditions printed, overleaf.

Licensing Authority
Seal of office

Condition of licence

1. This licence may be suspended or cancelled if any declaration made or information given in the application is not carried out.
2. No operations will be carried out for purposes other than those specified under item 7 (5) of the application for the licence and item 7(5) of the application for the certificate of approval.
3. All provisions of the Atomic Energy (Control of Irradiation of Foods Rules, 1996 shall be strictly complied with.
4. The irradiation facility shall not be transferred/sold/rented by me/us to another without the Prior permission of the competent authority.
5. No radiation source for the irradiation unit will be transported without the prior permission of the competent authority.
6. Full facilities will be accorded by me/us to any authorized representatives of The competent authority or the licensing authority to inspect the installations at any time.
7. Radiation surveillance and medical surveillance of all persons engaged in radiation work as required by the competent authority will be duly carried out at my/our expense.
8. All recommendations that may be made from time to time by the competent authority in respect of radiation safety measures will be duly implemented.
9. Duly qualified/experienced radiological safety officers/ operators/ quality officers will be appointed before the commencement of the operation of the facility.

10. Any changes in the personnel listed in this application will be intimated forthwith to the licensing authority and the competent authority.

11. The rules regarding decommissioning, disposal of decayed sources and reuse of the site of the decommissioned facility shall be strictly complied with.

12. A licence shall be valid for a period of three years from the date of issue of the licence.

- | | |
|---|---|
| <p>FORM V
[see rule 11 (1) and (4)]
Record of food irradiation</p> | <p>9. Nature, quality and quantity of food to be irradiated</p> <p>10. Purpose of irradiation</p> <p>11. Type of packaging used during radiation treatment, if any</p> <p>12. * Specific irradiation conditions used</p> <p>13. Any other incidents and anomalies observed during irradiation treatment.</p> <p>*Information necessary are: Commissioning, details, machine source) dose mapping for individual products, source position data, product loading pattern, conveyor operation, number and duration of process interruption, start and stopping time of processing and irradiation time.</p> |
| <p>1. Identification number of the irradiation facility</p> <p>2. Name and address of the operator and Quality Control Officer</p> <p>3. Serial number of the batch</p> <p>4. Date of irradiation</p> <p>5. Type of source radionuclide source or X-ray or electron</p> <p>6. Irradiation Dose</p> <p>7. Type of Dosimeters used and their calibration</p> <p>8. Minimum and Maximum limits of radiation dose</p> | |

[No. AE A[17[1]90-ER]
V. ASHOK, Dy. Secy. (ER)