

Radiation Protection Rules, 1971.

The Gazette of India
PUBLISHED BY AUTHORITY

NEW DELHI , SATURDAY OCTOBER 30,1971/KARTIKA 8, 1893

PART II Section -3 - Sub-Section 1

General statutory Rules (Including orders, bye-laws etc. of a general character) issued by the Ministries of the Government of India (other than the Ministry of Defence) and by Central Authorities (other than the Administration of Union Territories).

Department of Atomic Energy

Bombay, the 12th September 1971

G.S.R. 1601- In exercise of the powers conferred by section 30 of the Atomic Energy Act, 1962 (33 of 1962) and all other powers enabling it in this behalf, the Central Government hereby makes the following rules, namely: -

1. Short title, extend and commencement--

1. these rules may be called the Radiation Protection Rules, 1971.
2. they extend to the whole of India.
3. they shall come into force at once.

2. Definitions-- In these rules, unless the context otherwise requires, -

- a. "Act" means the Atomic Energy Act, 1962 (33 of 1962);
- b. "adequate protection" means protection against radiation so provided that the prescribed operational limits on levels of radiation or contamination are not exceeded;
- c. "appropriate" means appropriate in the opinion of the competent authority;
- d. "competent authority" means any officer or authority appointed by the Central Government by notification under these rules;
- e. "contamination" means the presence of radioactivity in quantities that may be specified as excessive by the competent authority by the notification for the purposes of these rules;
- f. "employer" means any person who employs radiation workers or who is self-employed as the only radiation worker in a radiation installation;
- g. "handle" means manufacture, possess, store, use, transfer by sale or otherwise, export, import, transport or dispose of;
- h. "operational limits" means limits on levels of radiation or on levels of contamination as the competent authority may by notification specify from time to time;
- i. "person" includes -
 - i. any individual, corporation, association of persons whether incorporated or not, partnership, estate, trust, private or public institution, group, government agency, or any state or any political subdivision thereof, or any political entity within the state, any foreign government or nation or

- any political subdivision of any such government or nation or other entity;
- ii. any legal successor, representative and agent of each of the foregoing;
- j. "radiation installation" means any location or facility which in the opinion of the competent authority requires radiation surveillance;
- k. "radiation surveillance" means measures that may be specified by the competent authority to provide adequate protection either generally or in any individual case;
- l. "radiation worker" means any person who is occupationally exposed to radiation and who, in the opinion of the competent authority, should be subject to radiation surveillance;
- m. "radiological safety officer" means any person who is designated by the employer and who in the opinion of the competent authority is qualified to discharge the functions outlined in rule 13;
- n. "sealed source" means any radioactive material which for purposes other than storage, transport or disposal is sealed in a container or bonded wholly within any material, in such a manner as to prevent the escape of the radioactive material having regard to its intended use, and includes the immediate container or the bonding;
- o. "source housing" means a shielding enclosure provided in any device containing the sealed source, in order to -
 - i. define the useful beam; and
 - ii. limit the radiation levels outside of the useful beam to maximum permissible leakage levels for such devices as may be specified by the competent authority by notification;
- p. "unsealed source" means any radioactive material other than a sealed source;
- q. "useful beam" means that part of emergent radiation from a sealed source which is capable of being used for the purpose for which the sealed source is intended;
- r. words and expressions used in these rules and not defined but defined in the act, shall have the meanings respectively assigned to them in the act.

3. Licensing:- No person shall handle any radioactive material except in accordance with the terms and conditions of a license granted to him in this behalf by the competent authority.

4. Rules not to apply in certain cases:- Nothing in these rules shall apply to the import, export, transport, possession, sale or use of timepieces, watches, instruments and other such devices containing luminous compounds in which radioactive materials have been incorporated, provided however that the exceptions specified above shall not apply to -

1. operations involving radioactive luminous compounds such as the manufacture or refinishing of the above mentioned devices;
2. such devices containing radioactive luminous compounds as may be specified by notification by the competent authority.

5. Prohibition of employment of persons below the age of 18 years:- No person under the age of eighteen years shall be employed as a radiation worker except with the prior permission in writing of the competent authority.

6. Conditions precedent for the issue of a license:- No license for handling radioactive materials shall be granted unless, in the opinion of the competent authority -

- a. the request for such license is for the purposes envisaged by the Act;
- b. the equipment, facilities and work practices afford adequate protection;
- c. the person in charge of the radiation workers possesses adequate qualification to direct the work.

7. Period of validity of a license:- Every license issued under these rules shall, unless otherwise specified, be valid for a period of three years from the date of issue of such license.

8. Power to revoke or modify a license:- The competent authority may, if it considers to do so in public interest revoke any license or modify the terms and conditions of the license at any time during the currency of license, after giving a show cause notice to the licensee and after giving him an opportunity to make a representation against the proposed action.

9. Power to withdraw a license:- Any license granted under these rules may be withdrawn at any time, if in the opinion of the competent authority, any of the provisions of these rules has been contravened, after giving a show cause notice to the licensee and after giving him an opportunity to make a representation against the proposed action.

10. Restrictions on the use of radioactive material:- No person shall use any radioactive material-

- a. for any purpose other than that specified in license;
- b. in any location different from that specified in license;
- c. in quantities exceeding those specified in license.

11. Offences and penalties:- Any person who contravenes any of the provisions of these rules or any of the terms and conditions of any license granted hereunder, shall be punishable as provided under section 24, section 25 and section 26 of the Act.

12. Radiological Safety Officer:-

1. Every employer shall designate, with the approval of the competent authority, either himself or a person under his employ as Radiological Safety Officer.
2. The Radiological Safety Officer shall, in addition to other duties that may be assigned to him by the employer, perform the duties and functions specified in rule 13.

13. Duties and functions of the Radiological Safety Officer:- The duties and functions of the Radiological Safety Officer in any radiation installation shall be as follows; namely:-

- a. to take all necessary steps aimed at ensuring that the operational limits are not normally exceeded;
- b. to instruct the radiation workers under his charge on the hazards of radiation and on suitable safety measures and work practices aimed at minimising exposure to radiation and contamination;
- c. to carry out leakage tests on sealed sources as specified in rule 34;
- d. to regulate the safe movement of all radioactive materials (including wastes containing radioactive materials) within the area under his charge;
- e. to investigate and initiate prompt and suitable remedial measures in respect of any situation that could lead to radiation hazards;

- f. to ensure that reports on all hazardous situations (including situations of the type referred to in rule 47 or as laid down in the notifications issued by the competent authority regarding operational limits) along with details of any immediate remedial measures that may have been initiated, are made available immediately to his employer;
- g. to ensure that the ultimate disposal of wastes containing radioactive materials is done in a manner approved by the competent authority.

14. Action to be taken by the employer in certain cases:- When an employer receives a report on any hazardous situation as provided under clause (f) of rule 13, he shall forthwith transmit such information to the competent authority.

15. Radiation surveillance:-

- 1. The competent authority shall, by notification specify appropriate radiation surveillance procedures and the employer shall comply with the same.
- 2. Without prejudice to the generality of the above power such procedures may provide that-
 - a. in any radiation installation, the planning, design, construction and operation of facilities involving the use of radiation shall be done with the prior approval of and in accordance with the specifications laid down by the competent authority;
 - b. the working conditions adopted and the monitoring and personnel protective equipment provided, shall be in accordance with the specifications laid down by the competent authority;
 - c. the radiation workers shall be subjected to personnel monitoring procedures specified by the competent authority;
 - d. the radiation workers shall be subjected to medical examination as provided in rule 19 or rule 20;
 - e. the appropriate records shall be maintained on the results of any routine measurements and investigations such as radiation and radioactivity level measurements, personnel monitoring measurements and medical examinations that may be stipulated by the competent authority;
 - f. an employer shall comply with any other special or general radiation surveillance procedures that may be specified by the competent authority.

16. Prior approval of the competent authority necessary in certain cases:- Any modification to any existing radiation installation or any change in working conditions therein shall be done only with the prior approval of the competent authority.

17. Radiation Symbol:-

- 1. The radiation symbol as shown below shall be prominently displayed in areas where exposure to radiation or contamination is likely and on all containers (including those used for transport) which contain radioactive material.

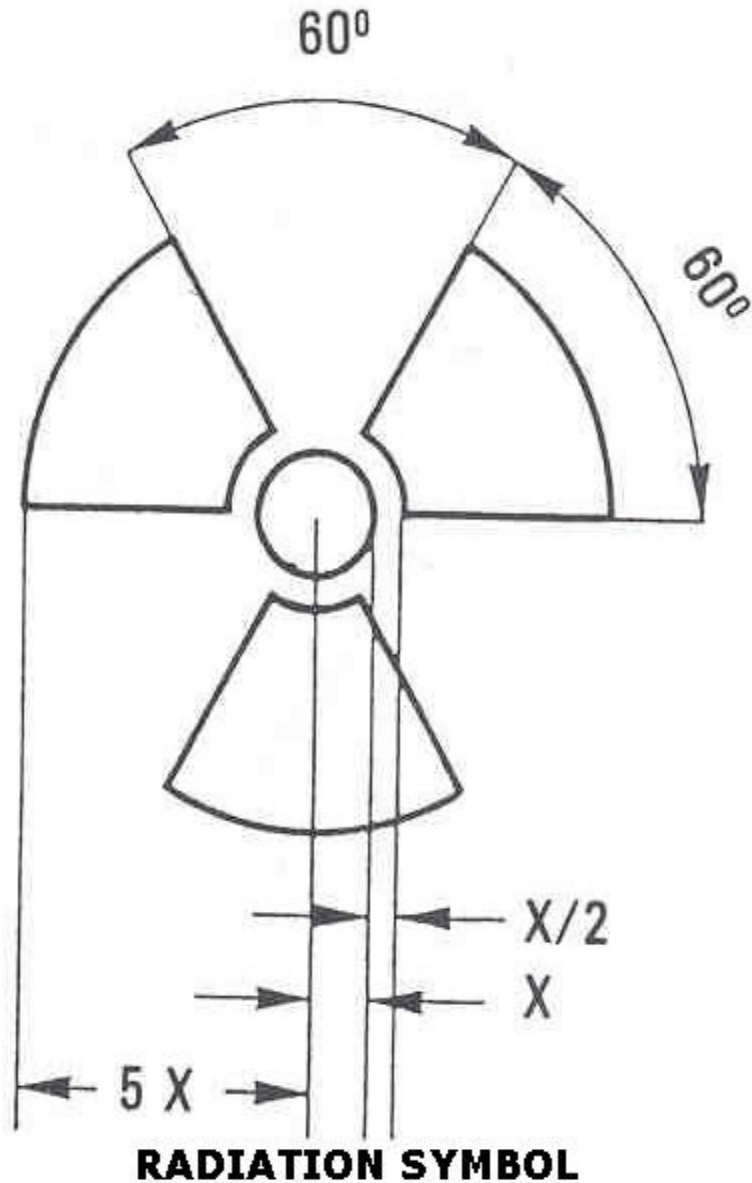

2. The above radiation symbol shall not be used for any purpose other than those mentioned in these rules.
3. The colours for the above radiation symbol shall be such as may be specified, by notification, by competent authority.

18. Duty of the employer to maintain certain history records of radiation workers:- Every employer shall maintain complete and up to date records of personal, medical and occupational histories of every radiation worker in such form as may be specified by the competent authority.

19. Medical examination of radiation workers:- Every radiation worker, prior to commencing radiation work, and subsequently at intervals not exceeding 12 months, shall be subjected to the

following medical examinations, and any other examinations which may be specified by the competent authority, namely:-

- a. X-ray examination of the chest;
- b. all general laboratory investigations such as the examination of blood and excreta;
- c. special investigations such as examinations of the skin, hands, fingers, nails and eyes.

20. Power of the competent authority to modify the medical examination of radiation workers:- the frequency and types of examinations specified in rule 19 may be modified by the competent authority, in special cases where such modification is considered by it necessary.

21. Duty of the employer to maintain complete medical records- complete records of the medical examinations specified in rule 19 or rule 20 shall be maintained by the employer.

22. Duty of the employer to send certain records to the competent authority when asked for:- Relevant excerpts from the records specified in the rule 15, rule 16 or rule 21 shall, on request, be sent by the employer to the competent authority in the form specified by it in this behalf.

23. Period of preservation of the records:- (1) The competent authority shall maintain appropriate records including results of personnel monitoring measurements and medical examinations in respect of every radiation worker for the period during which such worker is engaged in work involving exposure to radiation. (2) All such records as mentioned above shall be preserved for the duration of the life time of such worker, or for 20 years, after he ceases to do work involving exposure to radiation, whichever is shorter.

24. Power of the competent authority to requisition certain records:- all appropriate records of the type referred to in rule 23 which may have been maintained by any person prior to the coming into force of these rules may be requisitioned by the competent authority from the persons having the custody of the same.

25. Power of the competent authority to give directions in certain cases:- when in the opinion of the competent authority, any radiation worker has been subjected to radiation exposure in excess of the operational limits, the competent authority may specify appropriate steps to be taken for purposes of reducing the hazards and the employer shall comply with all the directions and orders of the competent authority in this behalf.

26. Duty of the employer to give alternative work to a radiation worker in certain cases:- If a radiation worker has to discontinue radiation work under the orders of the competent authority issued under rule 25, the employer shall make every reasonable effort to provide such a radiation worker with alternative work not involving exposure to radiation.

27. Resumption of radiation work by a radiation worker:- If a radiation worker is declared by the competent authority as fit to resume radiation work his employer shall permit him to resume radiation work.

28. Competent authority to plan the work of a radiation worker in certain cases:- when a radiation worker resumes radiation work as specified in rule 27, his subsequent work with radiation shall be as planned by the competent authority.

29. General power of inspection of radiation installation pursuant to section 14 or section 17 of the act, any person duly authorised by the competent authority may, for purposes of enforcement of these rules, inspect any radiation installation.

30. Inspection of new radiation installation:- Before the commencement of radiation work, every new or modified radiation installation may be inspected by any person duly authorised by the competent authority and may also be inspected at any time thereafter.

31. Powers of the person authorised to make inspection:- Any person duly authorised by competent authority under section 14 or section 17 of the Act, for the purposes of inspection, may

-

- a. inspect any radiation installation;
- b. inspect the work being conducted therein;
- c. inspect any permanently installed or movable protective device therein;
- d. inspect any transport or conveyance carrying radioactive materials;
- e. make such tests and measurements as may be necessary for purpose of evaluating radiation hazards;
- f. do all such things (including examination of relevant records) as he may consider necessary for purposes of determining the adequacy or otherwise of the methods employed and devices used therein for providing adequate protection.

32. Power to seal or seize radioactive material or give directions to the employer in certain cases:- Any person duly authorised by the competent authority under section 14 or section 17 of the Act may, after inspection, -

- a. seal any radiation installation or any transport or conveyance carrying radioactive materials or seize any radioactive materials or contaminated equipment;
- b. indicate in writing to the employer any modifications aimed at providing adequate protection and the employer shall comply with the same.

33. Sealed and unsealed sources:- Every employer shall maintain or cause to be maintained registers containing, inter alia the following particulars in respect of radioactive materials in his charge, namely:-

- a. in the case of sealed sources, the shape, size and distinguishing marks if any, of each sources;
- b. the activity with the date of measurement, physical and chemical forms, and dose rates, if any, at specified distances along with the date of measurement, of the various radioactive materials;
- c. the dates of receipt of radioactive materials;
- d. quantities of radioactive materials issued to various radiation workers along with dates;
- e. locations of the various radioactive materials in the working area;

- f. details of quantities of radioactive materials disposed of as waste along with dates and any other relevant date.

34. Duty of the Radiological Safety Officer to carry out certain tests:- The radiological Safety Officer shall carry out such tests for leakage on sealed sources and at such intervals as may be specified by the competent authority.

35. Precautions to be taken by the Radiological Safety Officer in the case of leakage of sealed sources :- In the event of the immediate container or bonding which forms part of a sealed source being cracked or broken, the Radiological Safety Officer shall –

- a. place the entire sealed source in a properly shielded leak-proof container; taking care to prevent spread of contamination;
- b. take all necessary measures to safeguard the radiation workers and others involved, including immediate vacation of all affected areas;
- c. take urgent steps to clean up any contamination;
- d. forthwith inform the employer of the details of the incident and of the remedial measures initiated, if any, for immediate onward transmission to the competent authority.

36. Loss of radioactive material:- If any radioactive material is found missing, the employer shall make immediate efforts to trace it, and the competent authority shall be informed immediately about the loss.

37. Telegamma sources to be provided with appropriate source housing:- All Telegamma sources shall be provided with appropriate source housing.

38. Designing of electrically operated telegamma units:- All electrically operated telegamma units shall be so designed that in case of power failure, the useful beam is automatically cut off.

39. Electrically operated telegamma units to be provided with manually operated devices: - All electrically operated telegamma units shall be provided with independent manually operated devices for interrupting the useful beam in case the electrical system for interruption fails.

40. Precautions to be taken by the medical institutions in certain cases – Every medical institution, where sealed or unsealed sources are used for treatment in such a manner that, as a result, the radioactive material remains on or inside the body of the patient, shall be provided with –

- a. separate rooms for carrying out the treatment;
- b. separate exclusive wards for patients so treated.

41. Precautions to be taken by the Radiological Safety Officer in the area where gamma radiography is done:- Where gamma radiography is done in an area where persons other than the radiation workers immediately involved in the operation are likely to be present, the Radiological Safety Officer shall cordon off suitable areas and control entry into those areas in such a manner as to ensure adequate protection.

42. Precautions to be taken regarding a sealed source:– Every sealed source used in industrial devices such as static eliminators thickness gauges, density gauges, package monitors and level gauges shall be provided with an adequate and efficient cover plate, shutter or shield, capable of being easily, securely and quickly operated in order effectively to attenuate the useful beam.

43. Use of fail-safe type of interlock switches:– Interlock switches used in radiation installations shall, if so specified by the competent authority, be of the fail-safe type.

44. Unsealed sources to be securely closed:– All containers containing unsealed sources shall be securely closed for preventing the escape of the material inside, and shall be properly labelled.

45. Precautions to be taken by the Radiological Safety Officer where unsealed sources are handled:– The Radiological Safety Officer shall ensure that in all work places where unsealed sources are handled–

- a. safe working methods are adopted;
- b. suitable facilities are provided for minimising radiation levels and surface and airborne contamination;
- c. undesirable working habits such as using mouth operated devices, working with open wounds, smoking, eating, drinking and the application of cosmetics are expressly forbidden;
- d. appropriate protective clothing under normal conditions and specialised clothing as and when necessary, is used;
- e. appropriate personal protective devices such as respirators, gas masks and airline suits are provided and that they are periodically inspected for wear and tear; hygienic and performance status and contamination;
- f. appropriate facilities for collection of wastes containing radioactive materials are provided.

46. Ventilation systems involving airborne contamination:– All ventilation systems involving airborne contamination shall be provided with appropriate ducts and filters aimed at avoiding spread or dispersal of any airborne contamination.

47. Spillage of radioactive material:– In the event of spillage of any radioactive material resulting in personal, surface or airborne contamination, the Radiological Safety Officer shall –

- a. take steps to arrange for the immediate decontamination of affected personnel;
- b. take steps to prevent any further spread of contamination;
- c. arrange for immediate decontamination of affected areas;
- d. forthwith inform the employer details of the incident and remedial measures initiated, if any, for immediate onward transmission to the competent authority.

48. Experiments on animals:– In radiation installations where sealed or unsealed sources are used in experiments on animals, appropriate facilities shall be provided for –

- a. the handling of such animals;
- b. the prevention of spread of contamination;
- c. the safe disposal of wastes containing radioactive materials.

49. Luminising compounds:- In radiation installations where luminising compounds containing radioactive materials are handled, appropriate facilities for ensuring radiation safety shall be provided.

50. Approved procedure to be adopted for mining, processing or fabrication of radioactive material:- The mining, processing or fabrication of radioactive materials and the disposal of wastes containing radioactive materials arising therefrom, shall be done only in accordance with the procedures approved by the competent authority.

51. Precautions to be taken in mining, processing or fabrication operations involving radioactive materials :- In mining, processing or fabrication operations involving radioactive materials –

- a. appropriate fixed or mobile monitoring devices or both shall be used to check environmental radiation levels at intervals specified by the competent authority;
- b. checks on personnel contamination shall be done by appropriate methods at appropriate intervals.

52. Disposal of animal carcasses and foliage containing radioactive material:- The handling and ultimate disposal of animal carcasses and foliage containing radioactive materials shall be done only in the manner approved by the competent authority.

53. Autopsies of cadavers containing radioactive material:- The performance of autopsies on, or the ultimate disposal of, cadavers containing radioactive materials, shall be done only in accordance with methods approved by the competent authority.

54. License for handling radioactive material:- Every person handling radioactive materials, shall, as required by rule 3, obtain licences from the competent authority within six months from the date of coming into force of these rules.

55. Employer to arrange monitoring of radiation workers:- Every employer shall arrange for appropriate personnel monitoring of all radiation workers under his charge within six months from the date of coming into force of these rules.

56. Power to exempt:- (1) The competent authority may exempt, for such periods of time as may be specified in the exemption order, any radiation installation from the applicability of any of the provisions of these rules or any of the provisions of notifications or orders issued thereunder. (2) The conditions under which such exemptions are granted shall be specified in the exemption order.

[No.

F.

6/3(3)/71-(P)]

B. BHAKTAVATSALU, Addl. Secy.